

Model 150-240

Double Reduction Planetary Gear Reducer

Flange Mount

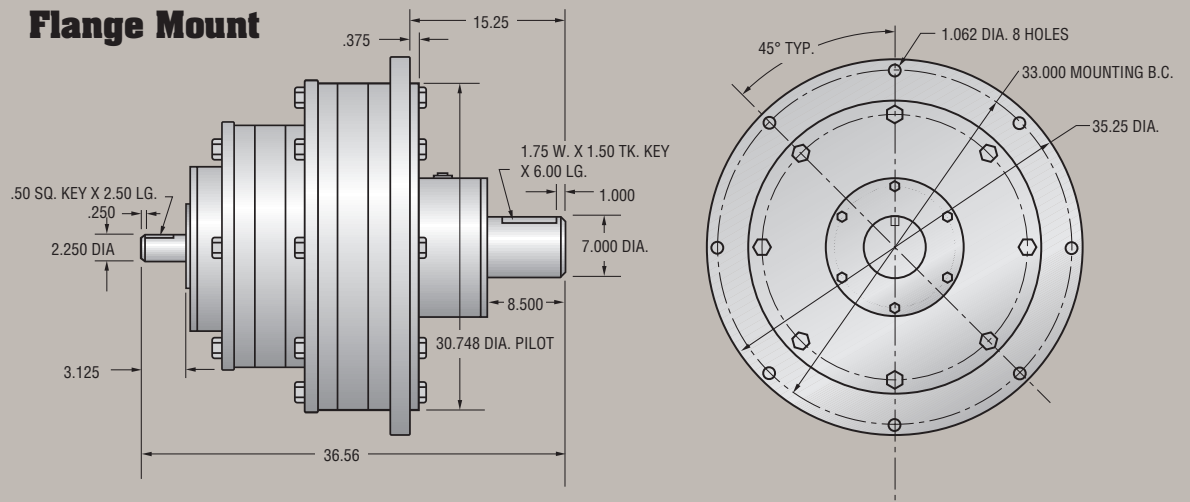

Foot Mount

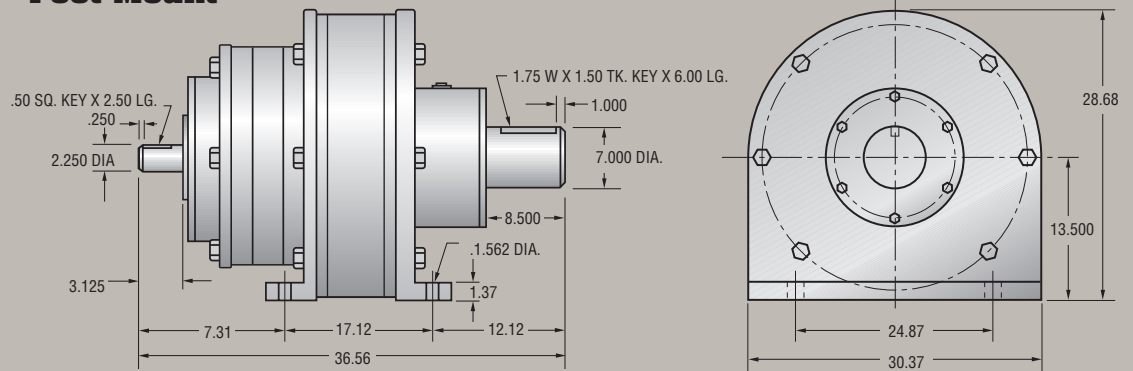

Flange or Foot Mount w/SAE or NEMA Input

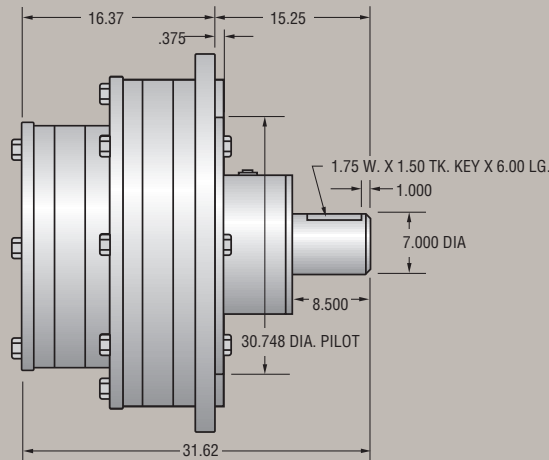

NEMA Electric Motor Direct Mount

"C" face direct couple of motor to speed reducer. No need for coupling or special motor mounts.

SAE Hydraulic Motor Direct Mount

2 bolt or 4 bolt direct couple of hydraulic motor to speed reducer. No need for coupling or special motor mounts.



Byrne
**Gear Corporation
of America**

- Planetary speed reducers
- High-speed increasers
- Custom design geared products

"The Problem Solver"

Model 150-240

Double Reduction Planetary Gear Reducer

Planetary Assembly	Ratios	OUTPUT HORSE POWER RATINGS (Adjusted for Thermal Efficiencies)						
		INPUT R.P.M.						
		100	580	720	870	1170	1430	1750
EE	9.00	90.93	311.23	362.09	413.37	508.64	585.35	674.22
EA	10.50	83.67	286.40	333.20	380.40	468.06	535.65	620.43
EB	12.00	74.34	254.46	296.05	337.98	415.87	478.58	551.25
AA	12.25	75.11	257.11	299.12	341.49	420.18	483.55	556.97
CE	13.00	70.29	240.60	279.91	319.56	393.21	452.51	521.21
AB	14.00	76.00	260.13	302.64	345.51	425.13	489.24	563.53
CA	15.17	64.68	221.40	257.58	294.07	361.84	416.40	479.63
BB	16.00	69.22	236.92	275.63	314.67	387.19	445.59	513.24
CB	17.33	65.44	224.01	260.61	297.53	336.10	421.31	485.28
DE	18.00	55.97	191.59	222.89	254.46	313.11	360.33	415.04
CC	18.78	45.92	157.17	182.85	208.75	256.85	295.59	340.47
DA	21.00	51.51	176.30	205.11	234.16	288.13	331.58	381.92
DB	24.00	52.11	178.38	207.52	236.92	291.52	335.48	386.42
DC	26.00	36.56	125.15	145.60	166.22	204.53	235.37	271.11
DD	36.00	27.97	95.75	111.40	127.17	156.48	180.08	207.42

Ratings based upon uniform steady and moderate shock loading. See load factor chart for details.

OUTPUT SHAFT RADIAL (overhung) LOAD CAPACITIES (at output r.p.m.)								
R.P.M.	10	20	30	50	100	200	300	500
Radial Capacity (lbs.)	56,000	46,000	40,000	35,000	28,000	27,000	23,000	19,000

OUTPUT SHAFT THRUST LOAD CAPACITIES (at output r.p.m.)								
R.P.M.	10	20	30	50	100	200	300	500
Thrust Capacity (lbs.)	52,374	41,942	37,681	32,319	26,260	21,335	18,889	16,200

OUTPUT SHAFT MAXIMUM CONTINUOUS TORQUE CAPACITY: 403,360 lb./inches
OUTPUT SHAFT INTERMITTENT TORQUE CAPACITY: 806,720 lb./inches
WEIGHT: 2,000 lbs.
RATING SYSTEM: All Ratings Based Upon American Gear Manufacturers' Association Standards



Byrne

GEAR CORPORATION OF AMERICA

301 Byrne Gear Drive
P. O. Box 1789
Mansfield, Ohio 44901
Telephone: (419) 522-GEAR(4327)
Fax: (419) 525-2386
E-mail: byrne@byrnegroup.com
Visit our web site at: www.byrnegroup.com

"The Problem Solver"

Part of The Byrne Group

Copyright © Byrne Gear Corporation of America
Printed in U.S.A. 697